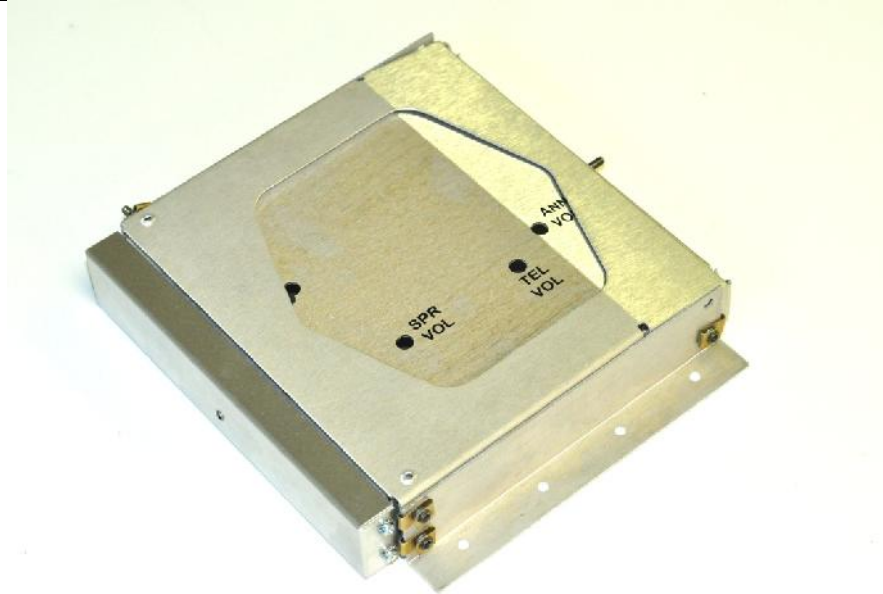




9800 Martel Road  
Lenoir City, TN 37772

[www.ps-engineering.com](http://www.ps-engineering.com)

# PAC15EX



Document P/N 200-015-0000

Revision 1, January 2014

Remote-Mounted Audio Controller with  
High-fidelity Stereo Intercom  
**System Installation and Operation Manual**  
Patented under one or more of the following;  
**No. 4,941,187; 5,903,227; 6,160,496 and 6,493,450**

***For use in Experimental/LSA/Non-certified aircraft ONLY***  
Not intended for installation in aircraft with standard airworthiness certification  
**The product warranty is not valid unless this product is installed by an  
Authorized PS Engineering dealer.**

PS Engineering, Inc. 2014 ©  
Copyright Notice

Any reproduction or retransmittal of this publication, or any portion thereof, without the expressed written permission of PS Engineering, Inc. is strictly prohibited. For further information contact the Publications Manager at PS Engineering, Inc., 9800 Martel Road, Lenoir City, TN 37772. Phone (865) 988-9800, email [contact@ps-engineering.com](mailto:contact@ps-engineering.com).

Table of Contents

Section I – GENERAL INFORMATION 1-1

|            |  |            |
|------------|--|------------|
| <b>1.1</b> | <b>INTRODUCTION</b> .....                        | <b>1-1</b> |
| <b>1.2</b> | <b>SCOPE</b> .....                               | <b>1-1</b> |
| <b>1.3</b> | <b>EQUIPMENT DESCRIPTION</b> .....               | <b>1-1</b> |
| <b>1.4</b> | <b>APPROVAL BASIS — <u>NONE</u></b> .....        | <b>1-1</b> |
| <b>1.5</b> | <b>SPECIFICATIONS</b> .....                      | <b>1-2</b> |
| <b>1.6</b> | <b>EQUIPMENT SUPPLIED</b> .....                  | <b>1-2</b> |
| <b>1.7</b> | <b>EQUIPMENT REQUIRED BUT NOT SUPPLIED</b> ..... | <b>1-3</b> |
| <b>1.8</b> | <b>LICENSE REQUIREMENTS</b> .....                | <b>1-3</b> |

Section II - INSTALLATION 2-1

|             |  |             |
|-------------|--|-------------|
| <b>2.1</b>  | <b>GENERAL INFORMATION</b> .....                       | <b>2-1</b>  |
| 2.1.1       | SCOPE .....  | 2-1         |
| 2.1.2       | CERTIFICATION REQUIREMENTS .....                       | 2-1         |
| <b>2.2</b>  | <b>UNPACKING AND PRELIMINARY INSPECTION</b> .....      | <b>2-1</b>  |
| <b>2.3</b>  | <b>EQUIPMENT INSTALLATION PROCEDURES</b> .....         | <b>2-1</b>  |
| 2.3.1       | COOLING REQUIREMENTS .....                             | 2-1         |
| 2.3.2       | MOUNTING REQUIREMENTS.....                             | 2-1         |
| 2.3.3       | AUDIO CONTROLLER MOUNTING RACK INSTALLATION.....       | 2-1         |
| <b>2.4</b>  | <b>CABLE HARNESS WIRING</b> .....                      | <b>2-3</b>  |
| 2.4.1       | NOISE .....  | 2-3         |
| 2.4.2       | AUDIO CONTROLLER TRAY AND CONNECTOR ASSEMBLY .....     | 2-4         |
| 2.4.3       | INPUT POWER .....                                      | 2-4         |
| 2.4.4       | AUDIO CONTROLLER INTERFACE .....                       | 2-4         |
| 2.4.5       | "SWAP" MODE.....                                       | 2-4         |
| 2.4.6       | UNSWITCHED INPUTS .....                                | 2-4         |
| <b>2.5</b>  | <b>INTERCOM WIRING</b> .....                           | <b>2-5</b>  |
| 2.5.1       | ENTERTAINMENT INPUTS .....                             | 2-5         |
| 2.5.2       | ENTERTAINMENT MUTING.....                              | 2-5         |
| <b>2.6</b>  | <b>ADJUSTMENTS</b> .....                               | <b>2-6</b>  |
| <b>2.7</b>  | <b>MICROPHONE GAIN REDUCTION</b> .....                 | <b>2-6</b>  |
| <b>2.8</b>  | <b>REASSEMBLY</b> .....                                | <b>2-7</b>  |
| <b>2.9</b>  | <b>COMMUNICATIONS ANTENNA INSTALLATION NOTES</b> ..... | <b>2-9</b>  |
| <b>2.10</b> | <b>PAC15EX PIN ASSIGNMENTS</b> .....                   | <b>2-9</b>  |
| <b>2.11</b> | <b>POST INSTALLATION CHECKOUT</b> .....                | <b>2-10</b> |
| <b>2.12</b> | <b>UNIT INSTALLATION</b> .....                         | <b>2-10</b> |
| <b>2.13</b> | <b>OPERATIONAL CHECKOUT</b> .....                      | <b>2-10</b> |
| <b>2.14</b> | <b>FINAL INSPECTION</b> .....                          | <b>2-11</b> |

|  |            |
|--|------------|
| <b>Section III OPERATION</b>                                 | <b>3-1</b> |
| <b>3.1 SCOPE</b> .....                                       | <b>3-1</b> |
| <b>3.2 POWER AND FAIL SAFE (1)</b> .....                     | <b>3-1</b> |
| <b>3.3 COMMUNICATIONS TRANSMIT (XMT) SELECTION (2)</b> ..... | <b>3-1</b> |
| <b>3.4 COM AUDIO SELECTOR (3)</b> .....                      | <b>3-2</b> |
| <b>3.5 NAVAID AUDIO SELECTION (4)</b> .....                  | <b>3-2</b> |
| <b>3.6 INTERCOM OPERATION (8)</b> .....                      | <b>3-2</b> |
| 3.6.1 <i>INTELLIVOX®</i> VOX-SQUELCH .....                   | 3-2        |
| 3.6.2 INTERCOM VOLUME CONTROL (7).....                       | 3-3        |
| 3.6.3 INTERCOM MODES (8).....                                | 3-3        |
| <b>3.7 MUSIC MUTING (9)</b> .....                            | <b>3-3</b> |
| 3.7.1 MUSIC 2 MUTE CONTROL .....                             | 3-4        |
| <b>Section IV – Warranty and Service</b>                     | <b>4-1</b> |
| <b>4.1 WARRANTY</b> .....                                    | <b>4-1</b> |
| <b>4.2 FACTORY SERVICE</b> .....                             | <b>4-1</b> |
| Appendix B – PAC15EX Installation Drawings.....              | A          |
| <b>5.1 REMOTE MOUNTING</b> .....                             | <b>B</b>   |
| Appendix C – J1 Connector Interconnect A                     |            |
| Appendix D – J2 Connector Interconnect A                     |            |

| Rev | Date         | Change                       |
|-----|--------------|------------------------------|
| New | October 2012 | First Release                |
| 1   | January 2014 | Removed erroneous references |

## Section I – GENERAL INFORMATION

### 1.1 INTRODUCTION

The PAC15EX represents another evolutionary step in cockpit audio control and intercommunications utility. Using our patented *IntelliVox*® design and pilot programmable configurations, this marks the next level of audio control. This unit is designed specifically to be used as remote-mounted audio selector/intercom, controlled by specific integrated avionics suites for experimental aircraft.

Before installing and/or using this product, please read this manual completely. This will ensure that you will take full advantage of all the advanced features in the PAC15EX.

### 1.2 SCOPE

This manual provides detailed installation and operation instructions for the PS Engineering PAC15EX-series of Audio Selector Panel/Intercom Systems. This includes the following unit:

| <u>Model</u> | <u>Description</u>  | <u>PS Engineering Part Number</u> |
|--------------|---|-----------------------------------|
| PAC15EX      | Remote-mounted Audio Selector Panel with stereo intercom. | 050-015-0100                      |

### 1.3 EQUIPMENT DESCRIPTION

The PAC15EX is a state-of-the-art audio isolation amplifier and audio selector that contains an automatic voice activated (VOX) intercom system and serial data control by a integrated avioncs controller, such as an MFD. It can switch two transceivers (Com 1, Com 2) and two receivers (Nav 1, Nav 2).

There are four unswitched inputs, available for traffic or EGPWS, autopilot disconnect tones, and/or radar altimeter warning.

Remote MFD control can select the communication transceivers for the pilot and copilot position, and allows radio transmission. In "Split Mode" the PAC15EX has the ability to allow the pilot to transmit on Com 1 while the copilot can transmit on Com 2. A fail-safe mode connects the pilot headphone and microphone to COM 1 if power is removed for any reason, or if the power switch is placed in the Off (Fail-safe) position. Unswitched input #1 is also provided to the pilot headphone in fail-safe

A four-station voice activated (VOX) intercom is included in the PAC15EX. This system has PS Engineering's patented *IntelliVox*® circuitry that eliminates manual adjustments. The intercom system incorporates pilot isolate, all and crew modes, two independent stereo music inputs with "SoftMute™".

### 1.4 APPROVAL BASIS — NONE

**The PAC15EX is not intended, or approved for installation on US Registered Civilian Aircraft with normal airworthiness certificates.**

## 1.5 SPECIFICATIONS

|   |  |
|---|--|
| <b>DIMENSIONS:</b>  | Height: 1.3 in. (3.3 cm) Width: 6.25 in. (16.9 cm)<br>Depth behind panel 7.15 in. (18.16 cm) |
| <b>WEIGHT</b><br><i>PAC15EX Unit</i><br><i>Rack with connectors</i>       | 1.34 lb. (0.61 kg)<br>0.51 lb. (0.24 kg)   |
| <b>AUDIO CONTROLLER POWER REQUIREMENTS (Including Internal Lighting):</b> |  |
| <i>Voltage:</i>   | 11-33 VDC  |
| <i>Maximum Current:</i>   | 2.5 Amp (Externally protected by a 3A pull-type breaker)                                     |

| <b>Audio Controller Specifications</b>       |  |
|--|--|
| <i>Audio selector panel input impedance:</i> | 510 Ω  |
| <i>Input Isolation:</i>                      | -60 dB (min.)  |
| <i>Receiver Inputs:</i>                      | 4 (Com 1, Com 2, Aux 1, Aux 2)                           |
| <i>Unswitched Inputs:</i>                    | 4  |
| <i>Transmitter Selections:</i>               | 3 (Com 1, Com 2, Com1/2)                                 |
| <i>Headphone Impedance:</i>                  | 150 – 1000 Ω   |
| <i>Headphone Output:</i>                     | 38 mW each headset, no clipping <1% THD typical into 150 |
| <i>Microphone Impedance:</i>                 | 150 - 600 Ω  |
| <b>Intercom Specifications</b>               |  |
| <i>Intercom Positions:</i>                   | 4 places (with individual <i>IntelliVox</i> ® circuits)  |
| <i>Music Inputs:</i>                         | 2, (Independent, Stereo)                                 |
| <i>Music Muting:</i>                         | >-30 dB "Soft Mute" when Com or intercom active.         |
| <i>Distortion:</i>                           | <1% THD @ 38 mW into 150Ω                                |
| <i>Mic Freq. Response, 3 dB:</i>             | 300 Hz - 6000 Hz   |
| <i>Music Freq. Response, 3 dB:</i>           | 10 Hz – 26 kHz   |

## 1.6 EQUIPMENT SUPPLIED

1 ea. of the following items:

| Model   | Description   | Part Number  |
|---------|---|--------------|
| PAC15EX | PAC15EX Remote-mounted Audio Controller with intercom | 050-015-0100 |

Installation Kit: 250-015-0000, containing:

| Description                          | Quantity | Part Number  |
|--------------------------------------|----------|--------------|
| PAC15EX installation rack assembly   | 1        | 430-890-0040 |
| PAC15EX Rack back plate              | 1        | 430-890-0050 |
| 44-pin connector kit                 | 2        | 120-891-2045 |
| Backshell, connector                 | 2        | 625-025-2465 |
| Backshell Retainer                   | 2        | 431-891-0100 |
| 4 40 X 7/16 screw w/nylon patch      | 4        | 475-440-0007 |
| 4 40 X 3/8 screw w/lock washer       | 4        | 475-440-1038 |
| 4 40 X 1/8 screw w/lock washer       | 2        | 475-440-0001 |
| Solder Lug                           | 2        | 475-009-0001 |
| Cable Clamp                          | 1        | 625-001-0002 |
| #6-32 x 1/2" Flat head Philips screw | 6        | 475-632-0012 |
| #6-32 Clip Nut                       | 6        | 475-630-0002 |
| PAC15EX Horizontal Mounting Flange   | 2        | 430-200-0042 |
| PAC15EX Vertical Mounting Bracket    | 1        | 430-200-0070 |

### **1.7 EQUIPMENT REQUIRED BUT NOT SUPPLIED**

- a. Circuit Breaker: 1 ea; 3 amp PULL TYPE REQUIRED for PAC15EX
- b. Headphone Jacks (up to 4 Stereo, as Required)
- c. Microphone Jacks (up to 4 as Required)
- d. Headphones, 150  $\Omega$  (Stereo), up to 4 as required
- e. Microphones, up to 4 as required
- f. Interconnect Wiring, coaxial cable

### **1.8 LICENSE REQUIREMENTS**

None.

## Section II - INSTALLATION

### 2.1 GENERAL INFORMATION

#### 2.1.1 SCOPE

This section provides detailed installation and interconnection instructions for the PS Engineering PAC15EX Audio Controller with Intercom.

Please read this manual carefully before beginning any installation to prevent damage and post-installation problems. Installation of this equipment requires special tools and knowledge.

#### 2.1.2 Certification Requirements

##### NOTE

The PAC15EX is not approved for installation in aircraft with a standard airworthiness certificate.

### 2.2 Unpacking and Preliminary Inspection

Use care when unpacking the equipment. Inspect the units and parts supplied for visible signs of shipping damage. Examine the unit for loose or broken buttons, bent knobs, etc. Verify the correct quantity of components supplied with the list in Section 1.6 (B). If any claim is to be made, save the shipping material and contact the freight carrier. Do NOT return units damaged in shipping to PS Engineering. If the unit or accessories show any sign of external shipping damage, contact PS Engineering to arrange for a replacement. Under no circumstances attempt to install a damaged unit in an aircraft. Equipment returned to PS Engineering for any other reason should be shipped in the original PS Engineering packaging, or other UPS approved packaging.

### 2.3 Equipment Installation Procedures

#### 2.3.1 Cooling Requirements

Forced air-cooling of the PAC15EX is not required. However, the units should be kept away from heat producing sources (i.e. defrost or heater ducts, dropping resistors, heat producing avionics) without adequate cooling air provided.

#### 2.3.2 Mounting Requirements

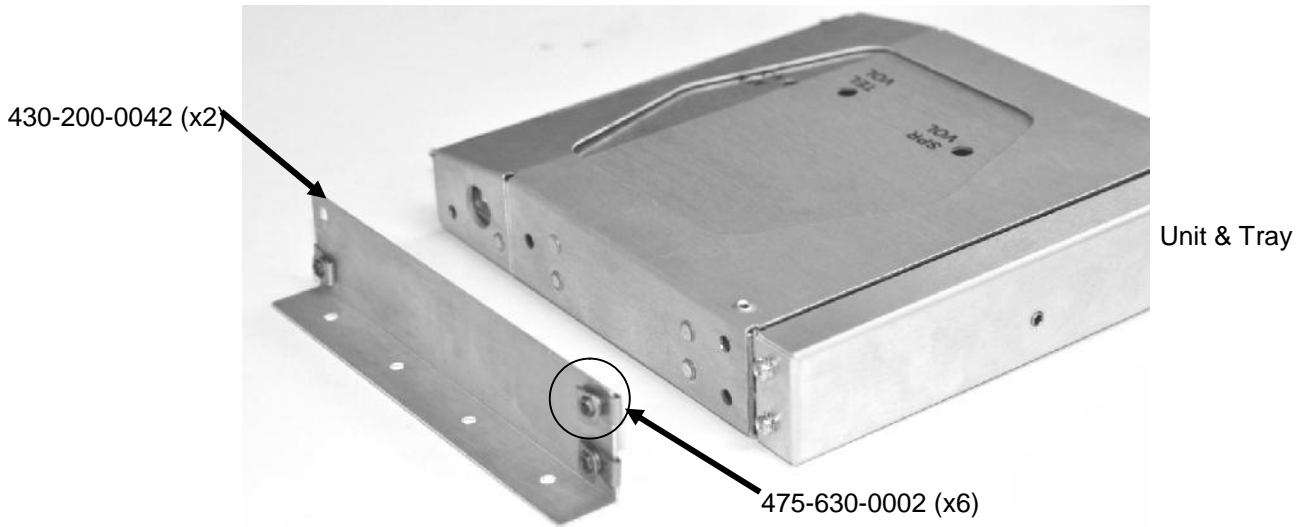
The PAC15EX must be rigidly mounted to the aircraft structure, The unit may be mounted in any area where adequate clearance for the unit and associated wiring bundle exist.

To prevent noise, avoid installing the unit close to high current devices or systems with high-voltage pulse type outputs, such as DME or transponders. Avoid running the interconnecting bundles near any high current wires.

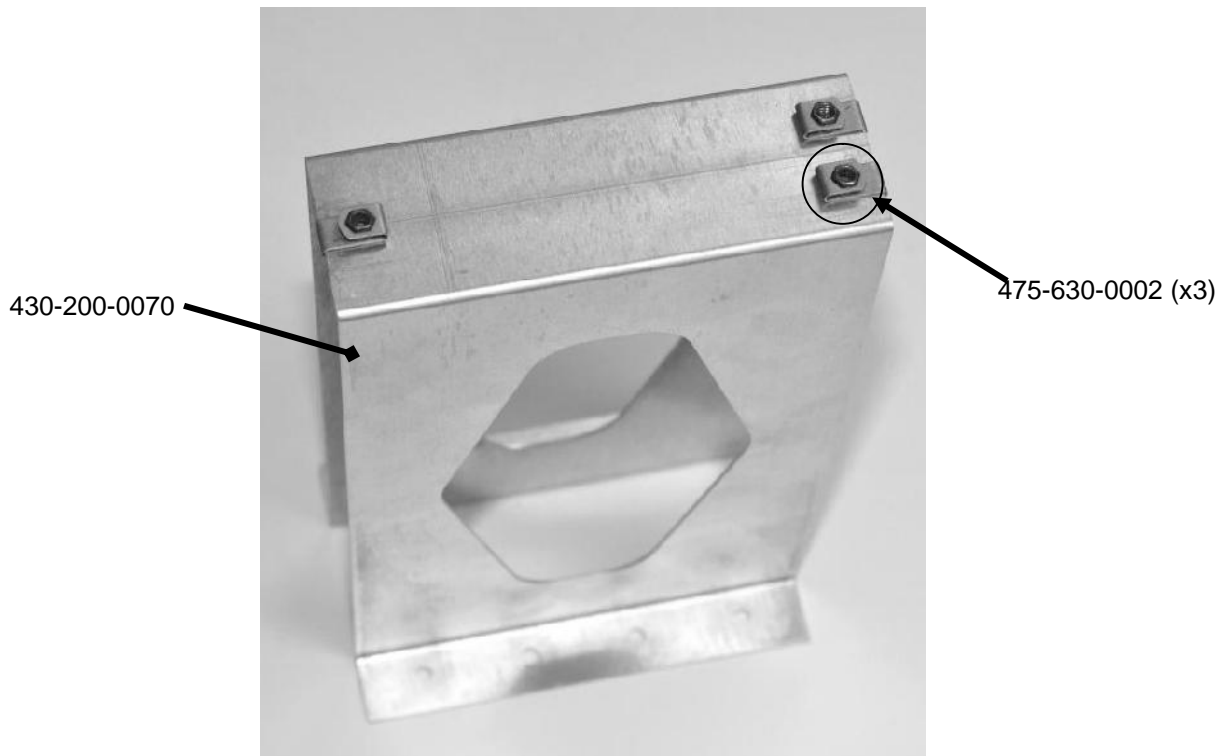
#### 2.3.3 Audio Controller Mounting Rack Installation

Remove the unit from the mounting tray by unscrewing the 3/32" hex-head screw that is in the center of the unit. Carefully slide the unit free of the tray. Set the unit aside in a safe location until needed.

The unit can be installed horizontally, with two mounting flanges (430-200-0042), six #6-32 clip nuts (475-630-0002), and six FHP 6-32 x 1/2" screws (475-632-0012). to attach the tray to the flanges with the screw head on the inside of the tray.

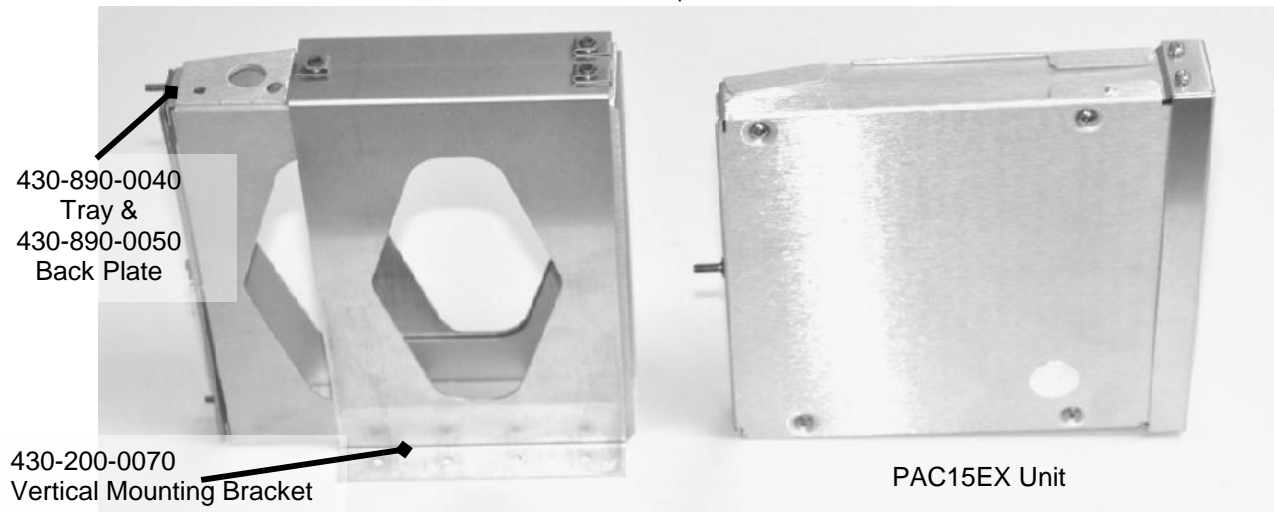


**Figure 2-1 Horizontal Mounting Flanges**



**Figure 2-2 Vertical Mounting Bracket**





The flanges can then be attached to the aircraft structure as appropriate. Refer to FAA AC 43.13-2B, Chapter 1 and 2 for more information.

## 2.4 Cable Harness Wiring

Referring to the appropriate Appendix, assemble a wiring harness as required for the installation. All wires must be MIL-SPEC in accordance with current regulations. Two- and three-conductor shielded wire must be used where indicated, and be MIL-C-27500 or equivalent specification. Proper stripping, shielding and soldering technique must be used at all times. It is imperative that correct wire be used.

Refer to FAA Advisory Circular 43.13-2B for more information. Failure to use correct techniques may result in improper operation, electrical noise or unit failure. Damage caused by improper installation will void the PS Engineering warranty.

### 2.4.1 Noise

Due to the variety and the high power of radio equipment often found in today's general aviation aircraft, there is a potential for both radiated and conducted noise interference.

The PAC15EX power supply is specifically designed to reduce conducted electrical noise on the aircraft power bus by at least 50dB. Although this is a large amount of attenuation, it may not eliminate all noise, particularly if the amplitude of noise is very high. There must be at least 13.8 VDC present at the connector, J2 pins 8 & 9, of the PAC15EX for the power supply to work in its designed regulation. Otherwise, it cannot adequately attenuate power line noise. Shielding can reduce or prevent radiated noise (i.e., beacon, electric gyros, switching power supplies, etc.) However, installation combinations can occur where interference is possible. The PAC15EX was designed in a RFI hardened chassis and has internal Electromagnetic Interference (EMI) filters on all inputs and outputs.

Ground loop noise occurs when there are two or more ground paths for the same signal (i.e., airframe and ground return wire). Large cyclic loads such as strobes, inverters, etc., can inject noise signals onto the airframe that are detected by the audio system. Follow the wiring diagram very carefully to help ensure a minimum of ground loop potential. Use only Mil Spec shielded wires (MIL-C-275000, or better). Under no circumstances combine a microphone and headphone wiring into the same shielded bundle. Always use a 2- or 3-conductor, shield wire as shown on the installation-wiring diagram.

The shields can be daisy-chained together, and then connected to the ground lugs mounted on the center of the back plate.

Radiated signals can be a factor when low level microphone signals are "bundled" with current carrying power wires. Keep these cables physically separated. It is very important that you use insulated washers to isolate the ground return path from the airframe to **all** headphone and microphone jacks.

### 2.4.1.1 Music Inputs and Noise

If a music jack is installed for Music 1 or 2, we strongly recommend isolating the jack from airframe ground, by using an insulated mounting plate.

**NOTE**

Adding a high-performance audio control system, particularly in conjunction with high-performance active noise canceling headsets, cannot improve on older avionics that were designed for cabin-speaker use. PS Engineering makes no claim that the Audio Controller will provide a noise-free audio quality under all installation conditions, particularly with older avionics.

### 2.4.2 Audio Controller Tray and Connector Assembly

The rack connectors mate with two 44-pin connectors in the PAC15EX. The connectors are a sub-miniature crimp-type, and require the use a hand crimp tool, from table below (or equiv.). The connectors are mounted to the tray back plate with #4-40 screws (475-440-1038), from the inside of the tray and the mounting block, 431-891-0100. Ensure that proper strain relief and chafing precautions are made during wiring and installation, using the cable clamp (625-001-0002).

| Manufacturer | Crimping Tool | Positioner   | Extraction tool |
|--------------|---------------|--------------|-----------------|
| AMP          | 601966-1      | 601966-6     | 91067-1         |
| Daniels      | AFM8          | K42          | M24308-1        |
| ITT-Cannon   | 995-0001-584  | 995-0001-739 | 91067-1         |

**Table 2-1 PAC15EX Connector Pin crimping tools**

### 2.4.3 Input Power

The PAC15EX is compatible with both 14 and 28 Volt DC systems. A three (3) Amp circuit breaker is required for all installations. Power and ground wires should be #22 connected to J2 Pins 8 and 9. Connect airframe ground to J2 Pin 10 and 11 only. No dropping resistors are required.

### 2.4.4 Audio Controller interface

The PAC15EX is designed to interface with standard aircraft avionics, and presents a 510 Ω receiver impedance. For best results, a twisted-shielded cable is recommended from the avionics audio source to the Audio Controller, with the shield grounded at the Audio Controller end.

Inputs A1 and A2 can be used to control navigation receiver audio, J1 Pins 17 WRT 18 and J1 19 WRT 20, respectively.

Some avionics do not provide a separate audio low, and may introduce additional electrical noise into the system. For best results, connect the audio low from the Audio Controller to the radio ground, using one conductor of the twisted-shielded cable.

### 2.4.5 "Swap" Mode

When a momentary, normally open, push-button switch is connected between pin 20 on the J2 connector and aircraft ground, the user can switch between Com 1 and 2 by depressing this switch without having to turn the mic selector switch. This yoke-mounted switch eliminates the need to remove your hands from the yoke to change transceivers.

### 2.4.6 Unswitched inputs

J1, pins 31, 29 and J2 pin 15 are unswitched, unmuted (by transmitter keying), inputs # 1, 3 and 4, respectively. These inputs are presented to the pilot and copilot regardless of the audio configuration, and will mute the entertainment inputs based on the mode. These 510 Ω inputs can be used for altimeter DH audio, GPS waypoint audio, autopilot disconnect tones, or any other critical audio signal. Unswitched #1 is always

presented to the crew headphones, and is available to the pilot in fail-safe (off) mode. Unswitched 3 and 4 inputs are always presented to the crew headphones.

| Unswitched Input | Input Pin | Hear in Fail Safe | Hear in Crew Headset | Gain       |
|------------------|-----------|-------------------|----------------------|------------|
| 1                | J1, 31    | Yes               | Yes                  | 1:1(fixed) |
| 2                | J1, 44    | No                | Yes                  | 1:1(fixed) |
| 3                | J1, 29    | No                | Yes                  | Adjustable |
| 4                | J2, 15    | No                | Yes                  | 1:1(fixed) |

Table 2-2 Unswitched input table

The audio low for unswitched #4 (J2, pin 15) should be connected to a convenient audio low such as J2, Pin 40. However, this should NOT be connected to Music Low (J2 pin 36 or 38).

Unswitched #1 (J1 Pins 31 & 32) is presented to the pilot headphone in fail-safe (off) mode.

**NOTE**

Inputs 1, 2 and 4 are fixed (1:1), and any audio level adjustments must be made at the input source. Unswitched #3 has a variable adjustment control located on the bottom side of the unit. This control allows you to control the volume level of that unswitched input from 50% to 200% of the input level. Refer to Adjustments section.

## 2.5 Intercom wiring

See Appendix C and D for intercom connection configurations. It is critical to the proper operation of this system to have this connector wiring made in accordance with these diagrams. Use 2- and 3-conductor, MIL-spec cable as shown. Connect the shields at the Audio Controller end only, and tie to the audio low inputs as shown.

**NOTE**

The system harness can be custom made by PS Engineering, Inc. Simply call the factory or [www.ps-engineering.com](http://www.ps-engineering.com) to obtain a wire harness work sheet. The harness will be made to your specifications and fully functionally tested. Harness can be ordered with jack, or without the intercom jacks installed, for easier wire routing through the aircraft.

### 2.5.1 Entertainment Inputs

The PAC15EX has two INDEPENDENT inputs wired into the rear connectors. Entertainment input number 1 is J2 pins 23 (left channel) and 24 (right channel), with respect to pin 25, and Entertainment number 2 is connected to 26 (left channel), 27 (right channel), with respect to 28.

**NOTE**

Use the low level output of any additional entertainment device to connect to the Audio Controller. Maximum signal level is **3 VAC** p-p. **DO NOT** use a speaker-level output, this will cause internal damage in the Audio Controller.

### 2.5.2 Entertainment muting

The PAC15EX-system incorporates a "Soft Mute™" system. This will mute the entertainment devices during ICS or radio conversation. The four muting modes are controlled by the MFD. See §3.7 for more information.

**CAUTION**

Local oscillators and internal signals from entertainment equipment can cause undesired interference with other aircraft systems. Before takeoff, operate the entertainment devices to determine if there is any adverse effect within the aircraft systems. If any unusual operation is noted in flight, immediately switch off the entertainment devices.

All entertainment devices must be switched off for both takeoff and landing.

#### 2.5.2.1 Entertainment 2 Mute (J2 Pin 13 & 14)

Connecting J2 pin 13 to pin 14 (or ground) through a SPST switch places the entertainment #2 music source into the Karaoke Mode. In this mode, incoming music and intercom conversation will not mute the music

for the passengers' intercom net. This allows uninterrupted music during casual conversation and at times when radio communications are of lesser importance.

## 2.6 Adjustments

The PAC15EX is factory adjusted to accommodate the typical requirements for most aircraft configurations. There are three adjustments in the top cover that allow the installer to tailor the specific functions.

- Unswitched Input 3 Volume, adjust from 50% to 200% of input value. (Bottom cover must be removed).

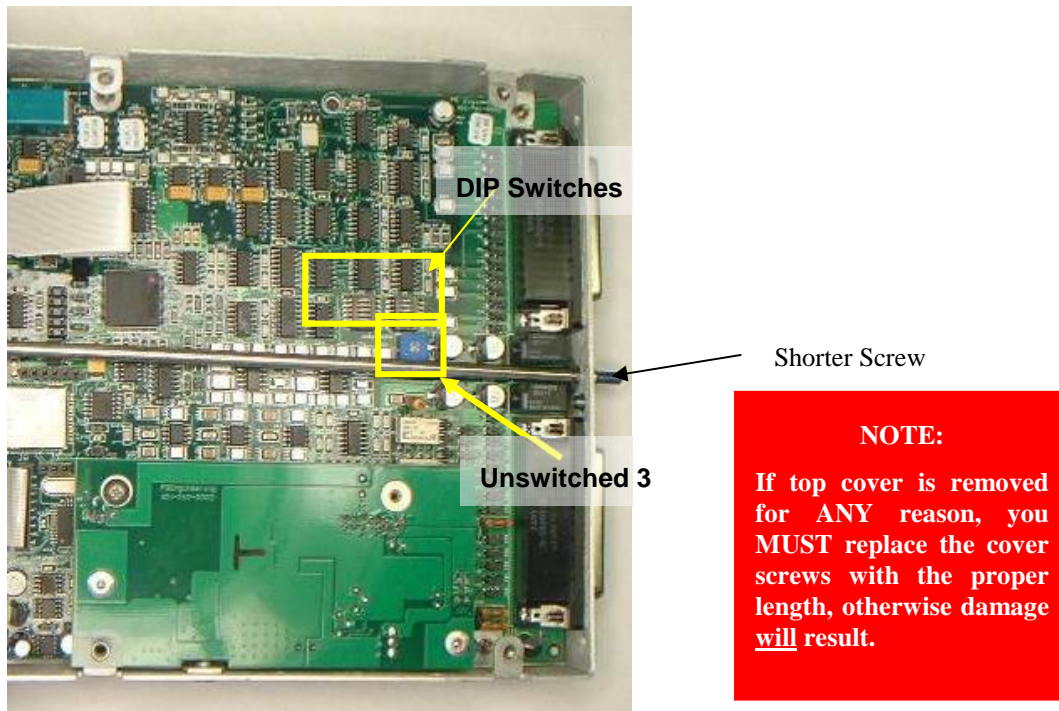


Figure 2-3 – PAC15EX DIP Switches

## 2.7 Microphone gain reduction

PAC15EX units Serial Number D01068 and above have the microphone gain set for noisy aircraft when shipped from PS Engineering.

For installations in very noisy aircraft, a reduction in the intercom microphone input gain is desirable. The PAC15EX has two DIP switches located on the main board that can switch the inputs to a lower gain setting.

Remove the top cover (see above), and locate the two DIP switches near the mounting rod at the rear of the unit.

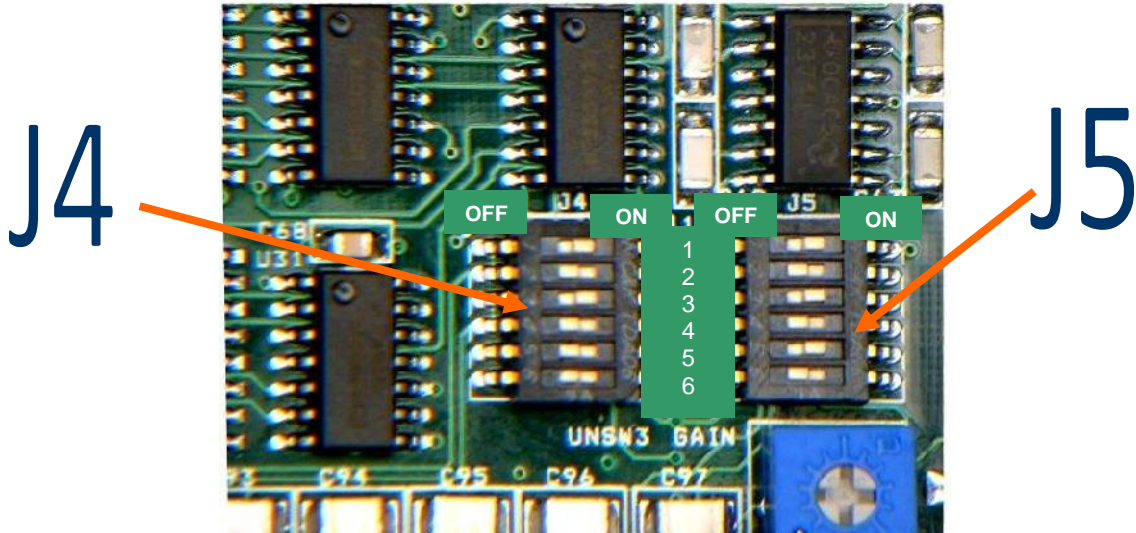


Figure 2-4 DIP switches

Change the settings as shown in the table below.

| Switch Bank                   | Switch | Noisy Cockpit | Normal Cockpit |
|-------------------------------|--------|---------------|----------------|
| <b>Pilot Microphone</b>       |        |               |                |
| J5                            | 1      | OFF           | ON             |
|                               | 2      | ON            | OFF            |
| <b>Copilot Microphone</b>     |        |               |                |
| J5                            | 3      | OFF           | ON             |
|                               | 4      | ON            | OFF            |
| <b>Passenger 1 Microphone</b> |        |               |                |
| J4                            | 1      | OFF           | ON             |
|                               | 2      | ON            | OFF            |
| <b>Passenger 2 Microphone</b> |        |               |                |
| J4                            | 3      | OFF           | ON             |
|                               | 4      | ON            | OFF            |

Table 2-3 Microphone gain settings

Carefully reassemble the unit.

## 2.8 Reassembly

1. Using the nylon spacers removed in step 2, compress them so they become oblong.

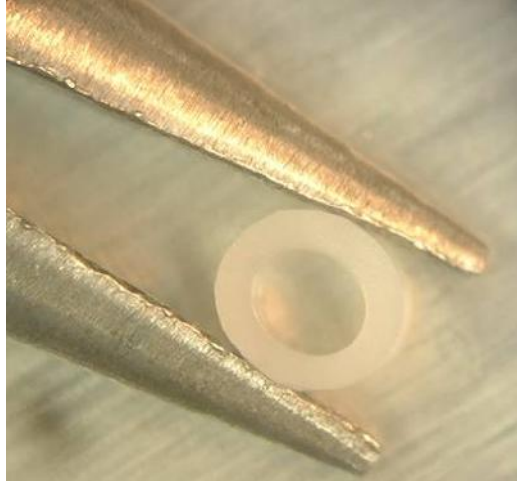


Figure #3

- a. Install one long screw through the top lid, near the front edge on the power supply board side, and add then add the nylon spacers from § 2.8.

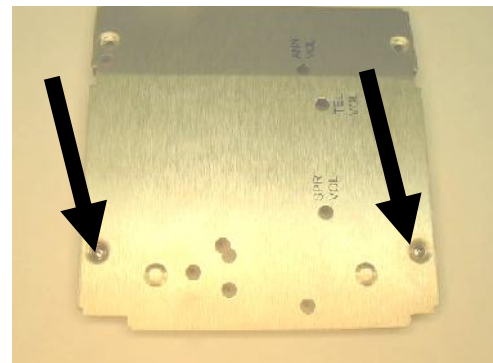
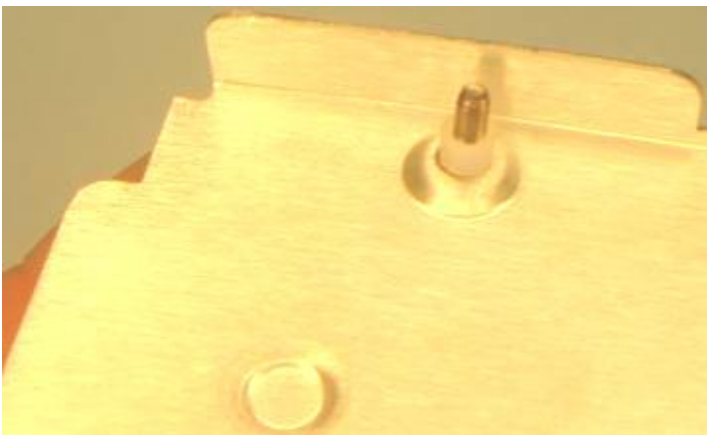
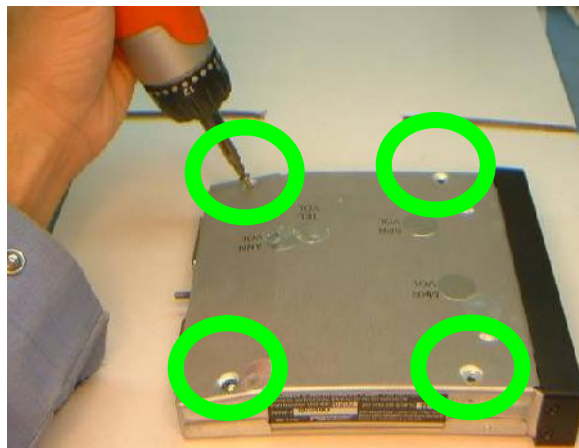


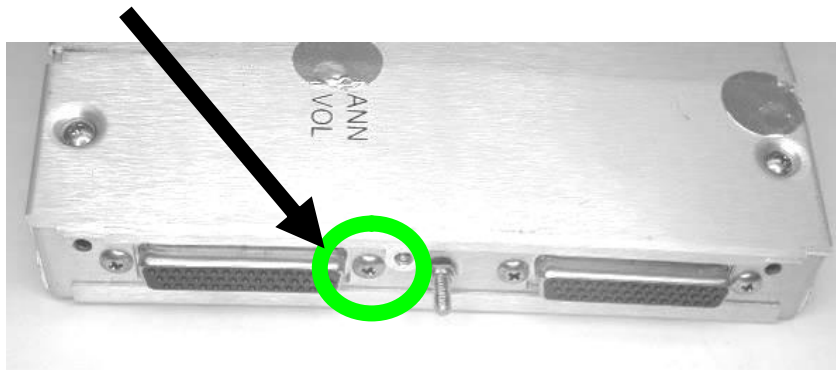
Figure #4

4. Place the lid back on the unit aligning holes.
5. Install qty. 2 more long thread screws into the lid.





6. Install qty. 1 short thread screw to the rear of the unit.



## 2.9 Communications Antenna Installation Notes

For best results while in Split Mode, it is recommended that the one VHF communications antenna is located on top of the aircraft while the other communications antenna is installed on the bottom. Any antenna relocation should be accomplished in accordance with AC 43.13-2B, and /or aircraft manufacturers' recommendations.

### WARNING

It is probable that radio interference will occur in the split mode when the frequencies of the two aircraft radios are adjacent, and/or the antennas are physically close together. **PS Engineering makes no expressed or implied warranties regarding the suitability of the PAC15EX in Split Mode.**

## 2.10 PAC15EX Pin assignments

| J1 | Function       | J2 | Function                |
|----|----------------|----|-------------------------|
| 1  | No Connect     | 1  | Pilot Phones Lo         |
| 2  | No Connect     | 2  | Copilot Phones Lo       |
| 3  | No Connect     | 3  | Copilot Phones (L)      |
| 4  | No Connect     | 4  | Copilot Phones (R)      |
| 5  | No Connect     | 5  | No Connect              |
| 6  | No Connect     | 6  | No Connect              |
| 7  | No Connect     | 7  | No Connect              |
| 8  | No Connect     | 8  | Aircraft Power          |
| 9  | Com 1 Audio    | 9  | Aircraft Power          |
| 10 | Com 1 Audio Lo | 10 | Aircraft Ground         |
| 11 | Com 1 Mic      | 11 | Aircraft Ground         |
| 12 | Com 1 Mic Key  | 12 | No Connect              |
| 13 | Com 2 Audio    | 13 | Music 2 Mute Inhibit    |
| 14 | Com 2 Audio Lo | 14 | Music 2 Mute Inhibit Lo |
| 15 | Com 2 Mic      | 15 | Unswitched #4           |
| 16 | No connect     | 16 | Pilot Phones (L)        |
| 17 | Aux 1 Audio    | 17 | <b>RS232 RXD</b>        |
| 18 | Aux 1 Audio Lo | 18 | No connect              |
| 19 | Aux 2 Audio    | 19 | No connect              |
| 20 | Aux 2 Audio Lo | 20 | Swap                    |
| 21 | No Connect     | 21 | No connect              |

**PS Engineering Inc. ®**  
PAC15EX Audio Selector Panel and Intercom System  
Installation and Operator's Manual

| <b>J1</b> | <b>Function</b>    | <b>J2</b> | <b>Function</b>      |
|-----------|--------------------|-----------|----------------------|
| 22        | Unswitched #3 Lo   | 22        | Music 1 All Headsets |
| 23        | No Connect         | 23        | Music 1 (L)          |
| 24        | No Connect         | 24        | Music 1 (R)          |
| 25        | No Connect         | 25        | Music 1 Lo           |
| 26        | No Connect         | 26        | Music 2 (L)          |
| 27        | No Connect         | 27        | Music 2 (R)          |
| 28        | No Connect         | 28        | Music 2 Lo           |
| 29        | Unswitched #3      | 29        | <b>RS232 TX</b>      |
| 30        | Com 2 Mic Key      | 30        | <b>No Connect</b>    |
| 31        | Unswitched Audio 1 | 31        | Pilot Phones (Rt)    |
| 32        | Unswitched Lo      | 32        | Copilot Mic Audio    |
| 33        | Pilot Mic Audio    | 33        | Copilot Mic PTT      |
| 34        | Pilot Mic PTT      | 34        | Copilot Mic Lo       |
| 35        | Pilot Mic Lo       | 35        | Pass 1 Mic Audio     |
| 36        | No Connect         | 36        | Pass 1 Mic Audio Lo  |
| 37        | No Connect         | 37        | Pass 2 Mic Audio     |
| 38        | No Connect         | 38        | Pass 2 Mic Audio Lo  |
| 39        | No Connect         | 39        | No Connect           |
| 40        | Pass HP (L)        | 40        | Unswitched #4 Lo     |
| 41        | Pass HP (R)        | 41        | No Connect           |
| 42        | Pass HP Lo         | 42        | No Connect           |
| 43        | Unswitched 2 Lo    | 43        | No Connect           |
| 44        | Unswitched 2 Audio | 44        | No Connect           |

### 2.11 Post Installation Checkout

After wiring is complete, verify power is ONLY on pins 8, and 9 of the J2 and airframe ground on connector pins 10, and 11. Failure to do so will cause serious internal damage and void PS Engineering's warranty.

### 2.12 Unit Installation

To install the PAC15EX, gently slide the unit into the mounting rack until the hold-down screw is engaged. While applying gentle pressure to the face of the unit, tighten the 3/32" hex-head in the center of the unit until it is secure. DO NOT OVER TIGHTEN.

**CAUTION**

Apply steady pressure to the front while screwing the unit into the tray to ensure even seating of the unit and connectors.

**WARNING**

Do not over-tighten the lock down screw while installing the unit in tray. **Internal damage will result.**

### 2.13 Operational Checkout

**NOTE**

The *IntelliVox*® is designed for ambient noise levels of 80 dB or above. Therefore some clipping may occur in a quiet cabin, such as without the engine running, in a hangar. This is normal.

1. Apply power to the aircraft and avionics.
2. Plug headsets into the pilot, copilot, and occupied passenger positions.
3. Verify fail-safe operation by receiving and transmitting on com 1 from the pilot position, with the Audio Controller power off. The Com and Unswitched #1 audio will be present in one ear cup only.
4. Apply power to the unit.



5. Check intercom operation.
6. Select COM 1 for transmitting on the MFD.
7. Verify proper transmit and receive operation from the copilot position, noting that the copilot PTT switch allows proper transmission on the selected transceiver.
8. Verify that the Com 2 receiver to be selected and heard. Verify operation on Com 1 from the pilot position.
9. Repeat for Com 2
10. Verify that the split mode can be invoked from the MFD, and verify that the pilot can transmit and receive on Com 1, while the copilot transmits and receives on Com 2.
11. Verify proper operation of all receiver sources by selecting them using the appropriate means. The A1 and A2 indicators illuminate to show which navigation audio source is in use.
12. Verify that the appropriate transmit indicator is active when either push to talk is keyed.
13. Verify proper Intercom system operation in the **ALL**, **ISO** and **CREW** modes (see Table 3-1).
14. Verify that the audio selector panel system does not adversely affect any other aircraft system by systematically switching the unit on and off, while monitoring the other avionics and electrical equipment on the aircraft.

### **2.14 Final Inspection**

Verify that the wiring is bundled away from all controls and no part of the installation interferes with aircraft control operation. Move all controls through their full range while examining the installation to see that no mechanical interference exists. Verify that the cables are secured to the aircraft structure in accordance with good practices, with adequate strain relief. Ensure that there are no kinks or sharp bends in the cables and coaxial cables. Verify that the cables are not exposed to any sharp edges or rough surfaces, and that all contact points are protected from abrasion.

Return completed warranty registration application to PS Engineering, or complete online at [www.ps-engineering.com](http://www.ps-engineering.com).

## Section III OPERATION

### 3.1 SCOPE

This section provides detailed operating instructions for the PS Engineering PAC15EX, Audio Controller Systems. Please read it carefully before using the equipment so that you can take full advantage of its capabilities.

This section is divided into sections covering the basic operating areas of the PAC15EX systems. They are Communications Transceiver Selection, Audio Selector, Intercom, and entertainment.

Operation is completely dependent on the specific display that the PAC15EX is interfaced with. Please refer to the operating guide for your installation.

### 3.2 Power and Fail Safe (1)

When power is not applied to the Audio Controller, the pilot headset is connected directly to Com 1 as well as unswitched input #1. This allows communication capability regardless of unit condition. Any time power is removed or turned OFF, the audio selector portion will revert to fail-safe mode.

The power switch controls all audio selector panel functions and the intercom. All pushbutton selections and menu modes will be remembered and return to the last state when turned on.

### 3.3 Communications Transmit (XMT) Selection (2)

The microphone selector section of the MFD controls which communications radio is selected for transmit. The receiver controls allows selection of the receiver audio.

The PAC15EX-Series has an automatic com receiver selector system. Audio from the selected transceiver is automatically heard in the headsets and speaker (if selected). This guarantees that the pilot will *always* hear the audio from the transceiver selected for transmit.

The PAC15EX “remembers” the receiver selection, so that when switching transmitters from COM 1 to COM 2, if COM 2 audio was previously selected, COM 1 audio will continue to be heard. This eliminates the pilot having to switch Com 1 audio back on, after changing transmitters.

When switching from COM 1 to COM 2 while Com 2 was not previously selected, COM 1 audio will be switched off. In essence, switching the mic selector will not override prior selection of COM receiver audio.

In normal (not split) modes, the PAC15EX gives priority to the pilot's radio Push-To-Talk (PTT). If the copilot is transmitting, and the pilot presses his PTT, the pilot's microphone will be heard over the selected com transmitter.

#### 3.3.1.1 Split Mode

The split mode can be selected at any time on the MFD. This places the pilot on COM 1 and the Copilot on COM 2.

Pilot on COM 2 and Copilot on COM 1 is not possible.

#### NOTE

Due to the nature of VHF communications signals, and the size constraints in general aviation aircraft, it is probable that there will be some bleed-over in the Split mode, particularly on adjacent frequencies. PS Engineering makes no warranty about the suitability of Split Mode in all aircraft conditions.

#### 3.3.1.2 Swap Mode (Switch from Com 1 to Com 2 remotely)

With a yoke mounted, normally open momentary switch, the pilot can change from the current Com transceiver to the other by depressing this switch. To cancel "Swap Mode," the pilot may either press the yoke mounted switch again, or select a different Com with the XMT buttons.

### 3.4 COM Audio Selector (3)

Communication audio from the other radio, not selected for transmit, can be heard by pressing the associated button. You will always hear the audio from the selected transceiver.

In SPLIT mode, only the pilot will hear selected navigation audio (A1 & A2).

### 3.5 Navaid Audio selection (4)

VHF Navigation receiver audio is selected through receiver control functions.

The MKR (Marker), ADF AUX (auxiliary) and DME audio is interfaced through an unswitched input.

### 3.6 Intercom Operation (8)

#### 3.6.1 IntelliVox® VOX-Squelch

No manual adjustment of the *IntelliVox*® squelch control is possible. Through individual signal processors, the ambient noise appearing in all four microphones is constantly being sampled. Non-voice signals are blocked. When someone speaks, only their microphone circuit opens, placing their voice on the intercom. The intercom can be configured for high noise environment by internal switching. See § 2.7 for more information.

The system is designed to block continuous tones; therefore people humming or whistling in monotone may be blocked after a few moments.

For consistent performance, any headset microphone **must** be placed within ¼-inch of your lips, preferably against them. (ref: RTCA/DO-214, 1.3.1.1 (a)).

**NOTE**

It is also a good idea to keep the microphone out of a direct wind path. Moving your head through a vent air stream may cause the *IntelliVox*® to open momentarily. This is normal.

The *IntelliVox*® is designed to work with normal aircraft cabin noise levels (70 dB and above). It loves airplane noise! Therefore, it may not recognize speech and clip syllables in a quiet cabin, such as in the hangar, or without the engine running. This is normal.

For optimum microphone performance, PS Engineering recommends installation of a Microphone Muff Kit from Oregon Aero (1-800-888-6910). This will not only optimize VOX performance, but will improve the overall clarity of *all* your communications.

**Table 3-1 Mic Muff™ Part Numbers**

| Manufacturer | Model               | Mic Muff™ Part Number |
|--------------|---------------------|-----------------------|
| Bose         | Dynamic             | 90010                 |
|              | Electret            | 90015                 |
|              | M87 Dynamic         | 90020                 |
| David Clark  | H10-30              | 90010                 |
|              | H10-20, H10-40      | 90015                 |
|              | H10-13.4            | 90015                 |
| Lightspeed   | All                 | 90015                 |
| Peltor       | 7003                | 90010                 |
|              | 7004                | 90015                 |
| Pilot        | 11-20 & 11-90       | 90015                 |
| Sennheiser   |                     | 90015                 |
| Telex        | Airman 750, Echelon | 90015                 |
|              | AIR3000             | 90010                 |

### 3.6.2 Intercom Volume Control (7)

The single volume control slider on the MFD adjusts the loudness of the intercom for the pilot, copilot, and passengers. It has no effect on selected radio or music input levels.

Adjust the radios and intercom volume for a comfortable listening level. Most general aviation headsets today have built-in volume controls; therefore, volume also can be further adjusted at the individual headset.

#### 3.6.2.1 Mono headsets in Stereo Installation

The pilot and copilot positions work with stereo or mono headsets. All passenger headsets are connected in parallel. Therefore, if a monaural headset is plugged in to a PAC15EX Stereo installation, one channel will be shorted. Although no damage to the unit will occur, passengers with stereo headsets will only hear in one ear, unless they switch to the “MONO” mode on their headset.

### 3.6.3 Intercom Modes (8)

The “ICS” control provides the selection of the three intercom modes.

**ISO:** The pilot is isolated from the intercom and is connected only to the aircraft radio system. He will hear the aircraft radio reception (and sidetone during radio transmissions). Copilot will hear passengers’ intercom and entertainment, while passengers will hear copilot intercom and entertainment. Neither will hear aircraft radio receptions or pilot transmissions.

When the Audio Controller is put into the “Split Mode” (pilot on COM 1, copilot on COM 2), the mute control becomes active. Toggle the mute control, and the intercom becomes active again. The intercom can be changed to the CRW or ALL mode if desired.

**ALL:** All parties will hear the aircraft radio and intercom. Crew and passengers will hear selected entertainment. During any radio or intercom communications, the music volume automatically decreases. The music volume increases gradually back to the original level after communications have been completed.

**CREW:** Pilot and copilot are connected on one intercom channel and have exclusive access to the aircraft radios. They may also listen to Entertainment 1. Passengers can continue to communicate with themselves without interrupting the Crew and may listen to entertainment as configured.

## 3.7 Music Muting (9)

There are two SoftMute™ muting circuits. The crew "Mute" control has four modes, and controls the Mute function for music 1. Music 2 muting is controlled by an external switch, and has two modes.

The SoftMute™ circuit will cut the music out whenever there is conversation on the radio, the intercom, or both, depending on the “Mute” mode selected. When that conversation stops, the music returns to the previous level comfortably, over a second or so.

The mute mode functions are controlled through the Mute command.

**MUTE ON** - music **will** mute with *either* intercom *or* radio – MUTE ON button is lit.

**RADIO MUTE** – Intercom will **not** mute music, radio *will* mute music. RAD LED indicator is on

**INTERCOM MUTE** - Radio will **not** mute music, intercom *will* mute music - MUTE ICS LED is ON.

**MUTE OFF** - “Karaoke” mode - music will not mute except during outgoing transmissions.- All Indicators off.

| Music           | Intercom | Radio | INDICATOR |
|-----------------|----------|-------|-----------|
| <b>Mute ON</b>  | Muted    | Muted | ON        |
| <b>Mute OFF</b> |          |       | None      |

**PS Engineering Inc. ®**  
PAC15EX Audio Selector Panel and Intercom System  
Installation and Operator's Manual

|                   |       |       |     |
|-------------------|-------|-------|-----|
| <b>Radio Mute</b> |       | Muted | RAD |
| <b>ICS Mute</b>   | Muted |       | ICS |

The passenger's intercom also has a SoftMute™ circuit. If the passengers hear the radio, or talk on the intercom, the music will mute. If the Audio Controller is in CREW mode, then the radio reception will not affect the passenger music.

### **3.7.1 Music 2 Mute Control**

Passengers also have a Karaoke Mode. If the passengers are listening to the music 1 input their Karaoke Mode is controlled by the crew "Mute" control. If the passengers are listening to the music 2 input, their Karaoke Mode is activated by an external switch.

## Section IV – Warranty and Service

### 4.1 Warranty

In order for the factory warranty to be valid, the installations **must be accomplished under the supervision of an authorized PS Engineering dealer. If the unit is being installed by a non-certified individual in an experimental aircraft, a PS Engineering authorized dealer, or factory-made intercom harness must be used for the warranty to be valid.**

PS Engineering, Inc. warrants this product to be free from defect in material and workmanship for a period of two (2) years from the date of sale. During the two-year warranty period, PS Engineering, Inc., at its option, will send a replacement unit at our expense if the unit should be determined to be defective after consultation with a factory technician.

All transportation charges for returning the defective units are the responsibility of the purchaser. All domestic transportation charges for returning the exchange or repaired unit to the purchaser will be borne by PS Engineering, Inc. The risk of loss or damage to the product is borne by the party making the shipment, unless the purchaser requests a specific method of shipment. In this case, the purchaser assumes the risk of loss.

This warranty is not transferable. Any implied warranties expire at the expiration date of this warranty. PS Engineering SHALL NOT BE LIABLE FOR INCIDENTAL OR CONSEQUENTIAL DAMAGES. This warranty does not cover a defect that has resulted from improper handling, storage or preservation, or unreasonable use or maintenance as determined by us. This warranty is void if there is any attempt to disassemble this product without factory authorization. This warranty gives you specific legal rights, and you may also have other rights, which may vary from state to state. Some states do not allow the exclusion of limitation of incidental or consequential damages, so the above limitation or exclusions may not apply to you.

All items repaired or replaced under this warranty are warranted for the remainder of the original warranty period. PS Engineering, Inc. reserves the rights to make modifications or improvements to the product without obligation to perform like modifications or improvements to previously manufactured products.

### 4.2 Factory Service

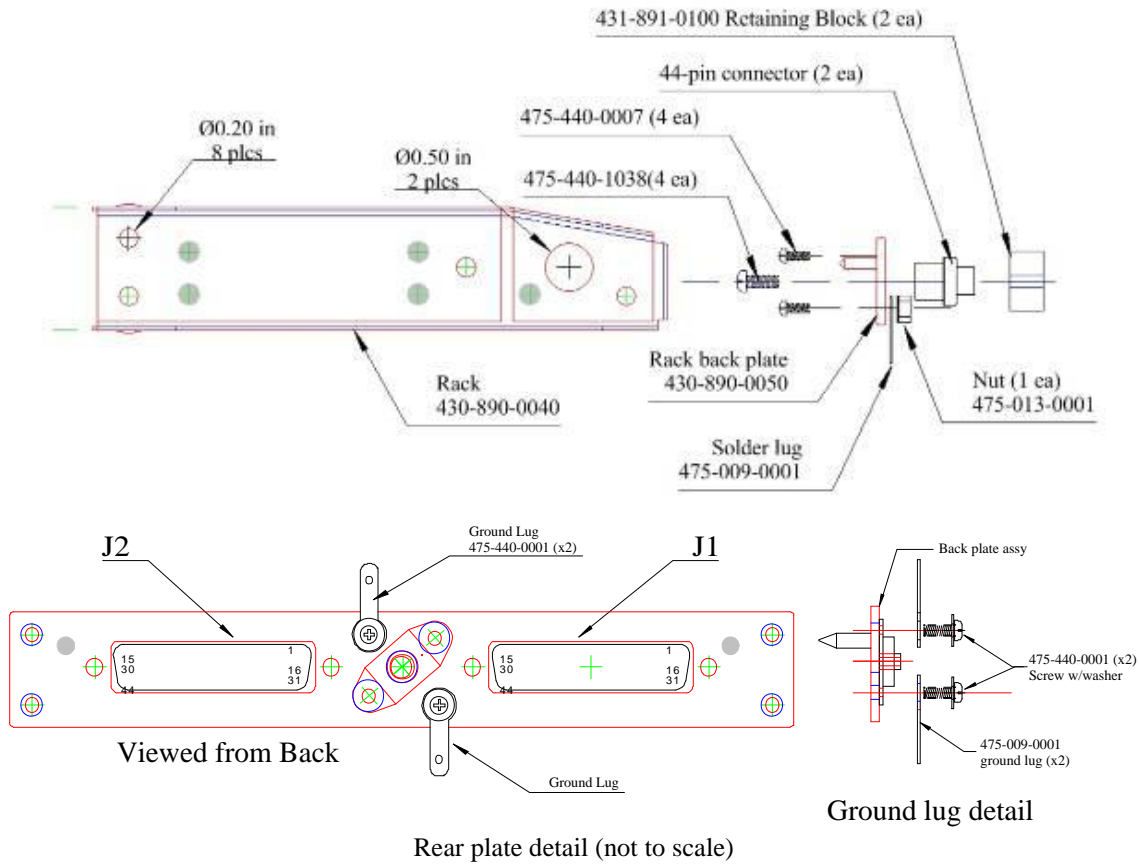
The units are covered by a two-year limited warranty. See warranty information. Call PS Engineering, Inc. at (865) 988-9800 before you return any unit. This will allow the service technician to provide any other suggestions for identifying the problem and recommend possible solutions.

After discussing the problem with the technician and you obtain a Return Authorization Number, ship product to:

PS Engineering, Inc.  
Attn: Service Department  
9800 Martel Rd  
Lenoir City, TN 37772  
(865) 988-9800 FAX (865) 988-6619  
Email: support@ps-engineering.com

**Units that arrive without an RMA number, or telephone number for a responsible contact, will be returned un-repaired. PS Engineering is not responsible for items sent via US Mail.**

## Appendix B – PAC15EX Installation Drawings



**Caution:** Apply steady pressure to the front while screwing the unit into the tray to ensure even seating of the unit and connectors. **At least one ground lug should be installed to prevent the unit from over insertion into the tray.**

### 5.1 Remote Mounting

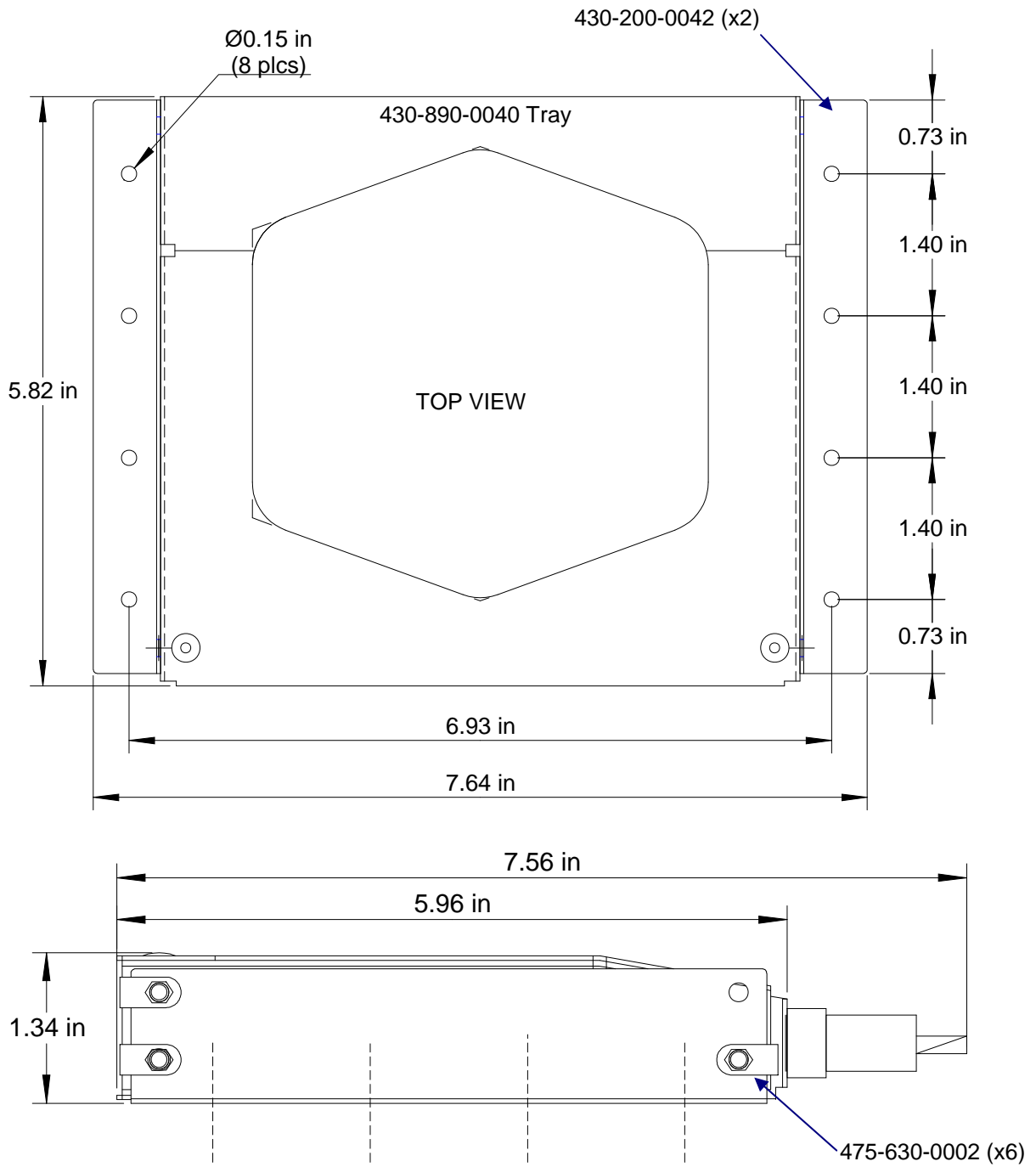


Figure 5-1 PAC15EX Mounting, Horizontal (Not to Scale)



PS Engineering Inc. ®  
PAC15EX Audio Selector Panel and Intercom System  
Installation and Operator's Manual

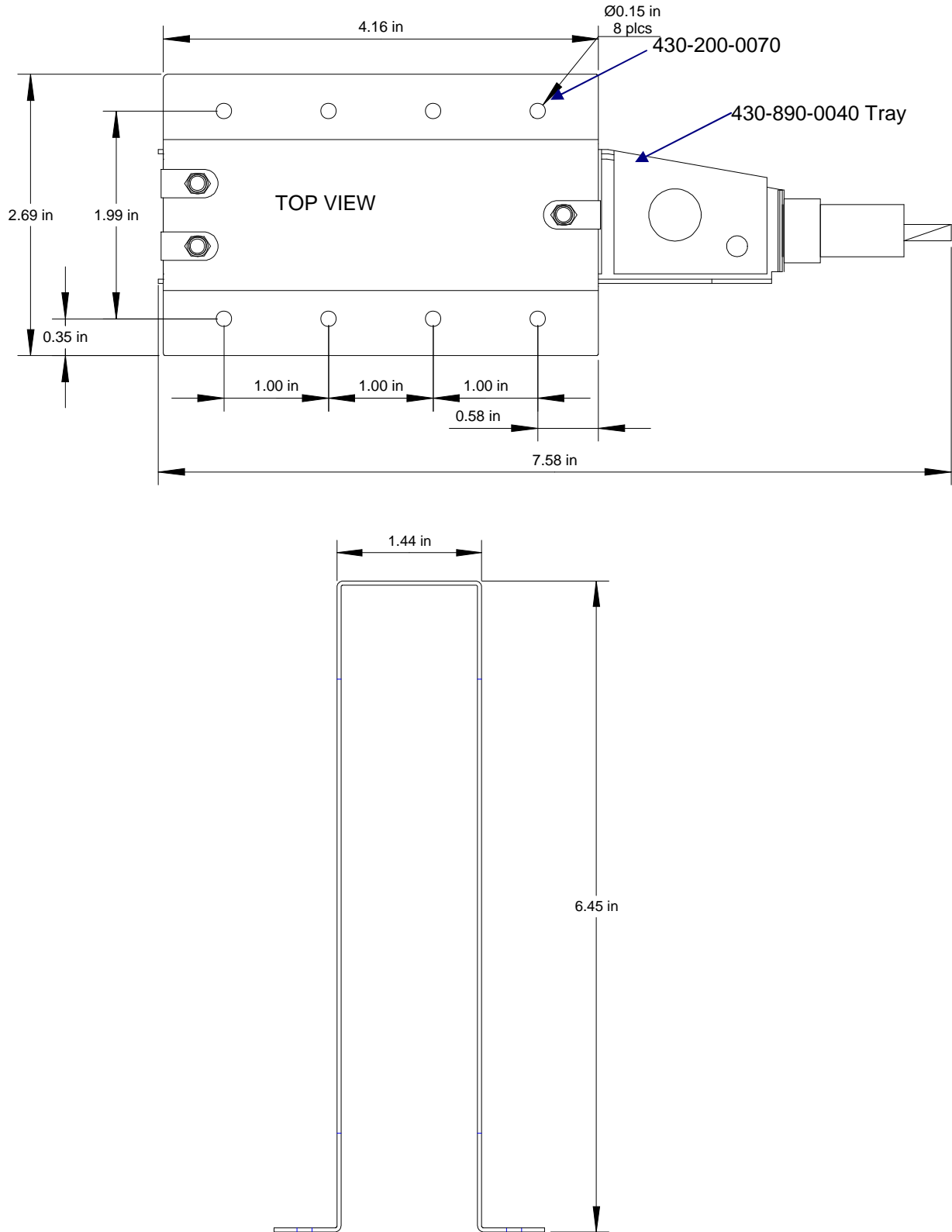
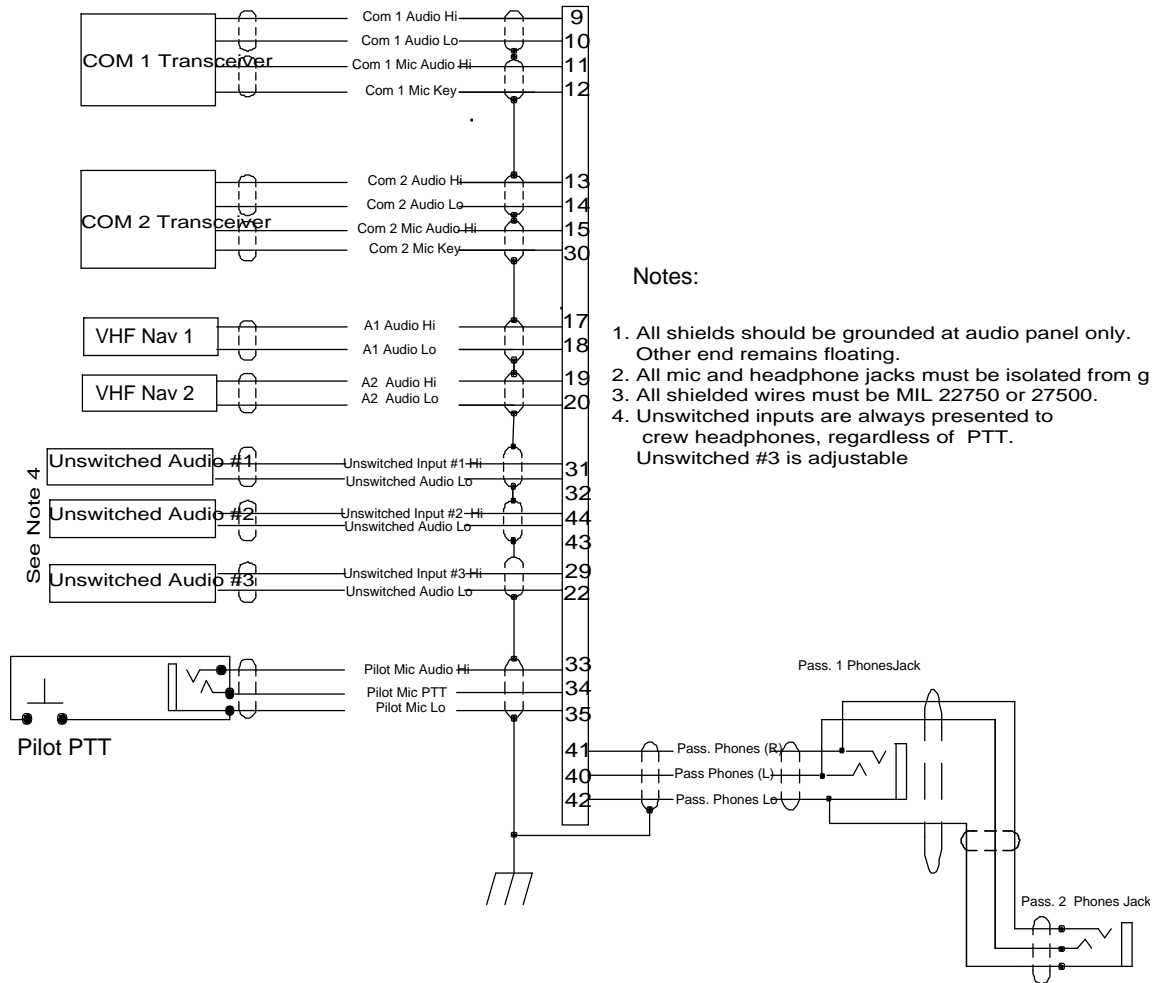


Figure 5-2 PAC15EX vertical Mounting Option (not to scale)

## Appendix C – J1 Connector Interconnect

PAC15EX Connector, J1 (Sub-D 44-pin, male on tray)



**Notes:**

1. All shields should be grounded at audio panel only. Other end remains floating.
2. All mic and headphone jacks must be isolated from g
3. All shielded wires must be MIL 22750 or 27500.
4. Unswitched inputs are always presented to crew headphones, regardless of PTT. Unswitched #3 is adjustable

## Appendix D – J2 Connector Interconnect

